

Residential

Vertical Platform Lift from Bruno

B R E A K I N G T H E B A R R I E R S

**Bruno Designed
and Bruno Built –
for complete
confidence and
reliability.**



Residential Vertical Platform Lift from Bruno

Now your porch or deck is totally accessible through this affordable solution from the leaders in residential accessibility technology.



Peace of Mind is not bought...it is given...through the skill, dedication, and vision of proud craftsmen who design and build products to increase the independence of people around the world.

Safety is the watch word.
Reliability is the standard.
Value is the promise.



The entire bottom of platform is spring sensitive, shutting the unit down if an obstruction is encountered.



Optional - Top landing gate includes mechanical interlock released only with platform at the top landing.

***“Bruno...First in Performance,
Built to Last!”***

VPL-3100 by Bruno
Making your life easier

fe • Durable

Affordable

The Bruno name has always meant trust. Our new Vertical Platform Lift extends that promise to another category of solutions "For your Independence".

For the consumer who insists upon performance and reliability, the Bruno VPL-3100 offers the perfect solution for your home accessibility needs.



Automatic self-lowering folding ramp provides convenient entrance for mobility devices when in the "down" position, and a safety barrier in the "up" position.

Simple, accessible controls with emergency stop switch are easy to operate.



Optional keyed call/send controls offer additional security and ease of operation.

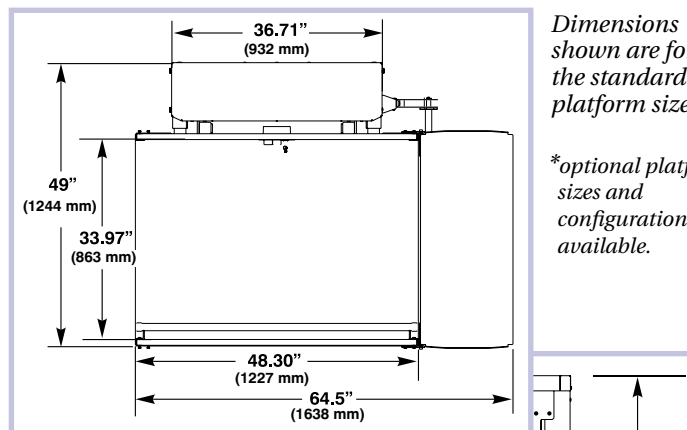

Dimensions shown are for the standard platform size.

**optional platform sizes and configurations available.*

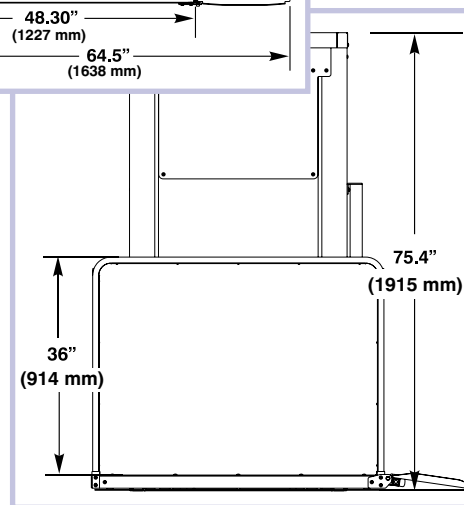

Dimensions shown are for the model VPL-3153

VPL-3100 Vertical Platform Lift Specifications

Standard Features

- Automatic self-lowering folding ramp
- Weather protected controls
- 750 lb/340 kg lifting capacity
- 53 in/1364 mm maximum floor to floor height (Model VPL-3153)
- 75 in/1905 mm maximum floor to floor height (Model VPL-3175)
- Separate up and down push-button switches with key switch control
- Emergency stop switch on platform – push to stop, pull to reset
- 1 HP motor, 1750 rpm, 110-120 Volt 15 Amp 60 Hz dedicated power
- Solenoid actuated screw breaking at the landings
- Welded steel tubular guide construction with formed 16 GA sheet steel guarding
- Totally enclosed bottom-formed steel safety pan
- Weather resistant powder coated paint throughout
- Acme screw drive, with safety back-up nut
- Bruno's Gold Warranty – Two year for major components and one year on parts.

Optional Equipment

- Top landing gate includes call/send controls with key and mechanical interlock (released only when platform is at top landing).
- Manual lowering hand crank
- Landing call/send station with key switch
- 90° Platform (adjacent exit at top landing)
- Paddle Controls

BRUNO INDEPENDENT LIVING AIDS, INC.®

manufactures independence products that help people live their lives to the fullest!

Ask us about our other...

INDOOR AND OUTDOOR STRAIGHT RAIL and CURVED RAIL *Stairlifts:*



ELECTRA-RIDE II™ Model SRE-2750



ELECTRA-RIDE III™ Model CRE-2100



OUTDOOR ELECTRA-RIDE™ Model SRE-2010E
**The only 400 lb/ 181.8 kg capacity outdoor stairlift...
 an INDUSTRY EXCLUSIVE!**

OVER 20 DIFFERENT *Vehicle Lifts* INCLUDING:



OUT-RIDER™ LIFT W/ POW'R TOPPER PACKAGE



**JOEY™ INTERIOR
 PLATFORM LIFT** VSL-4000



OUT-SIDER® MERIDIAN™ LIFT ASL-250



Founded over 20 years ago, Bruno Independent Living Aids, Inc., is a world-wide manufacturer of accessibility products designed to enhance the lives of those challenged by limited mobility. In pursuing this goal, Bruno is proud to be the only U.S. manufacturer of indoor/outdoor stairlifts, interior/exterior scooter, powerchair and wheelchair vehicle lifts and Turning Automotive Seating™ (TAS™) products to be ISO 9001 Certified. This is one of the most stringent, widely-recognized quality standards in the world and your assurance that Bruno is committed to providing you with the highest-quality, most reliable products in the industry. Ask your certified Bruno dealer for details on all Bruno independence products.



Represented by:

BRUNO INDEPENDENT LIVING AIDS, INC.®

1780 Executive Drive, P.O. Box 84, Oconomowoc, WI 53066
 (262) 567-4990 • FAX: (262) 953-5501 • www.bruno.com

*Revolutionary
 Turning Automotive
 Seating™ (TAS™)*



TURNY™ ORBIT® SEAT

All illustrations and specifications in this brochure are based on the latest product information available at the time of publication. Bruno Independent Living Aids, Inc. reserves the right to make changes at any time without notice. Vertical Platform Lift Brochure 10/08-3
 © Bruno Independent Living Aids, Inc. 2008.

